

## TILT SWITCH AND DISPLAY SYSTEM

### FEATURES

- ⇒ Compact, light weight, rugged
- ⇒ Angle measurement accuracy of 0.1 deg
- ⇒ Dual axis angle measurement
- ⇒ RS485 communication between devices
- ⇒ Low cost

### APPLICATIONS

- ⇒ Boom angle measurement in crane
- ⇒ Tipper angle measurement
- ⇒ Bucket angle monitoring and control in cherry pickers
- ⇒ Body angle measurement in off-road vehicles
- ⇒ Chassis angle measurement in special purpose vehicles
- ⇒ Tip over protection of dumper operating in rough terrain

### INTRODUCTION

High operational efficiency with clean safety record is the mission of companies in current times. The cut throat competition necessitates least down time caused by breakdown, maintenance and one unfortunate accident can ruin years of reputation. Reducing human involvement in mission critical operations or adding human with digital information using new edge sensor helps in achieving high efficiency and safety.

Aeron's Digital Tilt Switch and Display System does just what is needed in operation of cranes, dumper, trucks, cherry pickers and other similar vehicles. It measures angle of platform, chassis, boom, displays in operator's cabin and operates buzzer, hydraulics when angle reaches safe operational limits. The real time digital information available to operator helps in eliminating guess works and therefore resulting in continuous operation within safe limits.

The Tilt Switch and Display System ARN-TSWD consists of three devices, Digital Tilt Sensor, Controller Device and Display. The Digital Tilt Sensor measures the two angles while controller generates commands to activate relays at limit angles. The LED Display connects with tilt sensor and displays the two angles in real time.

The device has no moving parts, giving it long operational life without maintenance. It also has built in temperature sensors to compensate for temperature variations in different environmental conditions.



**DIGITAL TILT SENSOR: ARN-TS2D**

The Digital Tilt Sensor (ARN-TS2D) uses new age sensors employing MEMS accelerometers and embedded processing to give accurate information of Roll and Pitch angles in static or non-dynamic conditions. Following are the technical specifications of ARN-TS2D.

| Parameter           | Value/Type                  | Units          |
|---------------------|-----------------------------|----------------|
| Measurement Range   | ±60 (pitch)<br>±180 (roll)  | Degrees        |
| Resolution          | 0.01                        | Degrees        |
| Accuracy            | ±0.1                        | Degrees        |
| Output Rate*        | 1 - 50                      | Hz             |
| Power Supply        | +8 to +15                   | Volts DC       |
| O/P Format          | RS485                       | -              |
| Shock Survival      | 20                          | g <sup>#</sup> |
| Casing Material     | Aluminum block construction |                |
| Size                | 78 x 56 x 36                | mm             |
| Weight              | < 200                       | gm             |
| Working Temperature | -20 to +70                  | °C             |
| Connector           | Circular                    |                |

\* Default rate at 1 Hz, factory programmable, # Acceleration due to gravity

**CONTROLLER DEVICE**

The Controller Device has two relay outputs to operate buzzer or solenoids. It receives the two angles from Digital Tilt Sensor, data is given to onboard processor, an algorithm running in the processor gives activation commands to relays when the angles reach their respective limits in longitudinal and transverse axis. The device can also give five numbers TTL output for indicating both angles with range, Roll angle exceeded in negative, Roll angles exceeded in positive, Pitch angle exceeded in negative and Pitch angle exceeded in positive.

| Parameter            | Value/Type  | Units |
|----------------------|---|-------|
| Roll angle limit     | ±2  | deg   |
| Pitch angle limit    | ±5  | deg   |
| Power supply         | +8 to +15   | VDC   |
| Data input interface | Digital serial RS485                                | -     |
| Output type~         | 2 Nos. Relay (for Roll, Pitch)<br>5 Nos. TTL output |       |
| Relay rating         | 5A @ 110 VAC  | -     |
| Size                 | 125 x 80 x 57                                       | mm    |
| Weight               | < 450   | gm    |







~ factory selectable

**DIGITAL DISPLAY**

The Digital Display having 7 segment bright red color LEDs is visual indicator of Roll and Pitch angles. It displays the two angles in separate lines for easy readability. It's compact size allows it to be installed in operator's cabin.

| <b>Parameter</b>         | <b>Value/Type</b>    | <b>Units</b> |
|--------------------------|----------------------|--------------|
| Axes                     | Dual                 | -            |
| Angle display resolution | 0.1                  | deg          |
| Angle display range      | -99.0 to +99.0       | deg          |
| Display type             | 7 segment LED        | -            |
| Power supply             | +8 to +15            | VDC          |
| Data input interface     | Digital serial RS485 | -            |
| Size                     | 134 x 116 x 32       | mm           |
| Weight                   | 250                  | gm           |

**CONFIGURATIONS**

| Configuration 1   | Configuration 2  | Configuration 3  |
|---|--|--|
| <p>Three devices</p> <p>⇒ Tilt Sensor<br/>⇒ Controller device<br/>⇒ LED display</p>    | <p>Two devices</p> <p>⇒ Tilt sensor and Controller<br/>⇒ LED display</p>   | <p>One device</p> <p>⇒ Tilt sensor, control and display</p>  |

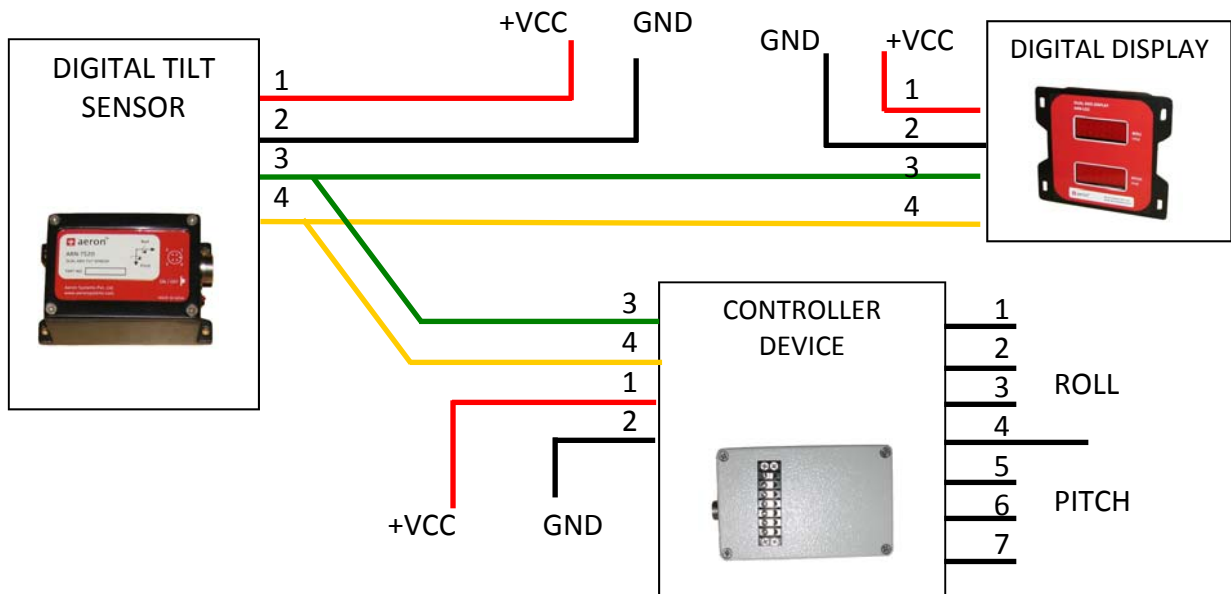
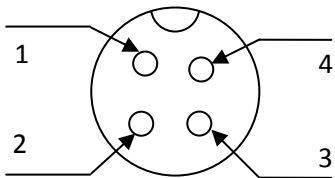
**CONNECTION DETAILS**

**PIN DIAGRAM: DIGITAL TILT SENSOR**

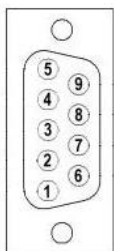
PIN 1: +VCC  
 PIN 2: GND  
 PIN 3: D+  
 PIN 4: D-

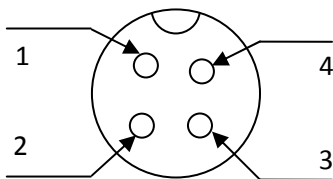
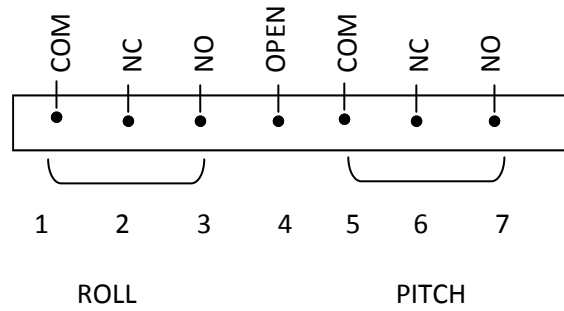

**PIN DIAGRAM: DIGITAL DISPLAY**

**DB9 MALE CONNECTOR**

PIN 1: OPEN  
 PIN 2: D+  
 PIN 3: D-  
 PIN 4, 5: OPEN  
 PIN 6: +VCC  
 PIN 7: GND  
 PIN 8, 9: OPEN

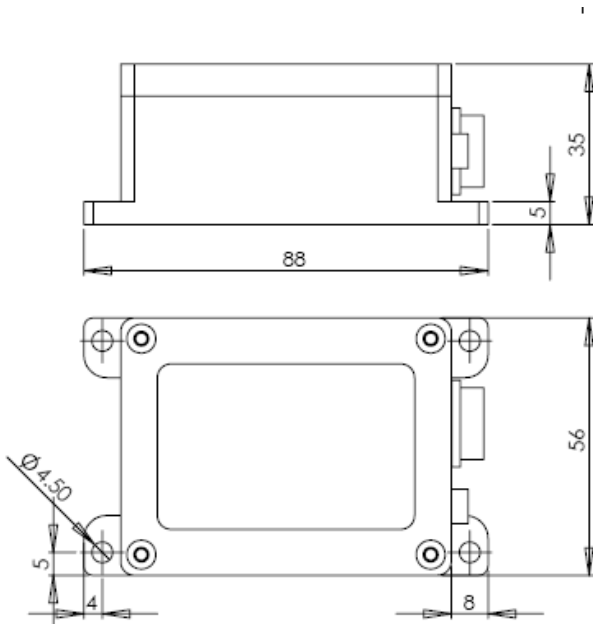
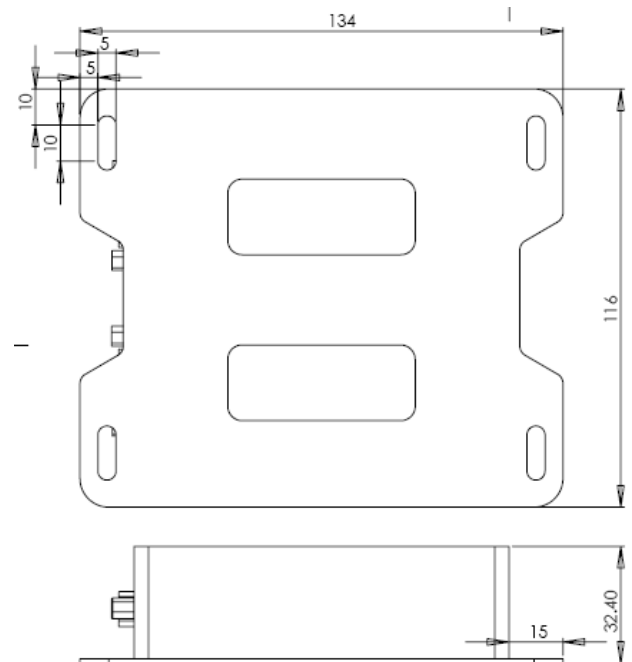
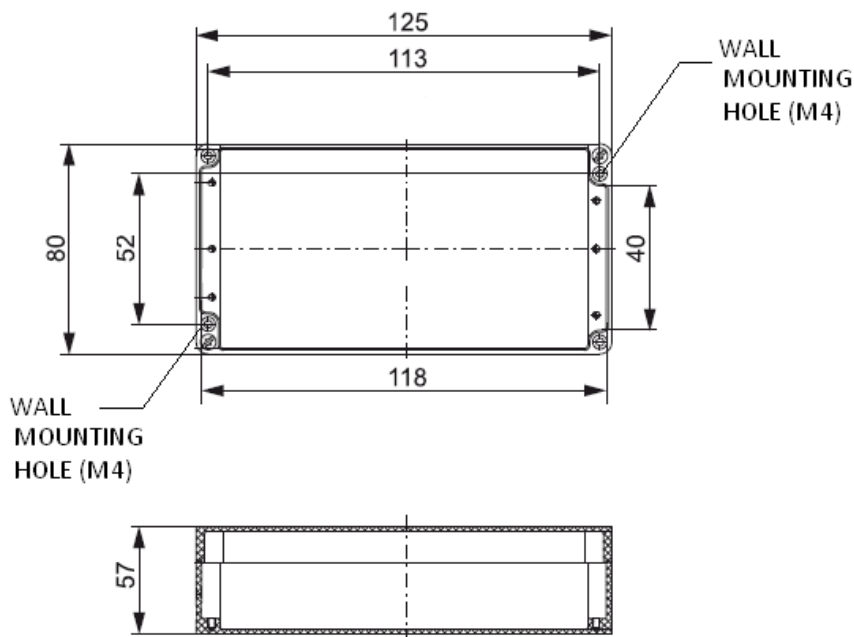

**PIN DIAGRAM: CONTROLLER DEVICE**

PIN 1: +VCC  
 PIN 2: GND  
 PIN 3: D+  
 PIN 4: D-

**DIMENSIONAL DRAWING:**
**DIGITAL TILT SENSOR (ARN-TS2D)**

**DIGITAL DISPLAY (ARN-LD2)**

**CONTROLLER DEVICE**

Note: All dimensions are in mm.